

LANGSTON BLACK

REAL ESTATE, INC.

COMMERCIAL BUILDING FOR LEASE

14370 EAST WADE HAMPTON BLVD (HWY 29), GREER

1,480+- SF BUILDING WITH LOTS OF PARKING

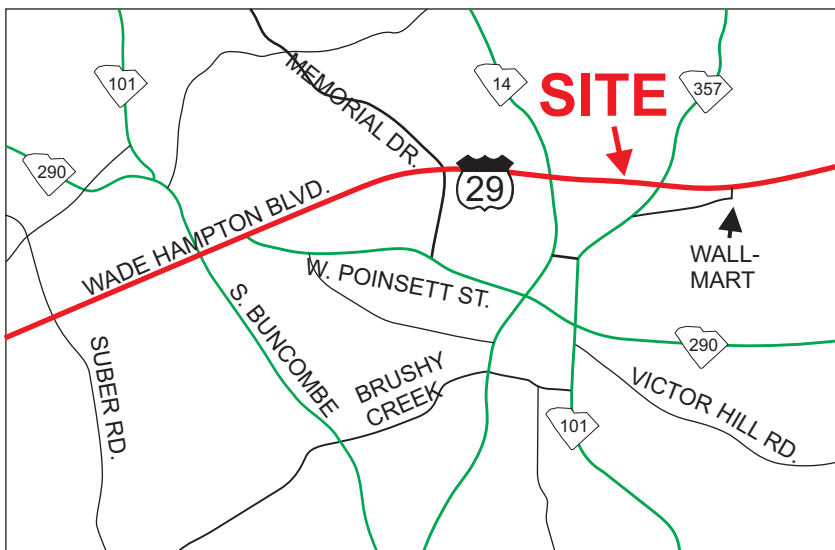

- 0.45+- ACRE PAVED LOT
- PORTION OF TAX MAP 9-03-10-020.00
- ZONED CITY OF GREER C3

FOR MORE INFORMATION CONTACT
CHUCK LANGSTON AT 864-230-4302
clangston@langston-black.com

LANGSTON BLACK
REAL ESTATE, INC.

P.O. BOX 2167
GREER, S.C. 29652
BUS: 864-848-9070

447

www.langston-black.com

Every effort has been made to ensure the accuracy of the enclosed data, but we assume no responsibility for errors. All conditions and pricing subject to change without notice.
(LANGSTON-BLACK SITE #447)

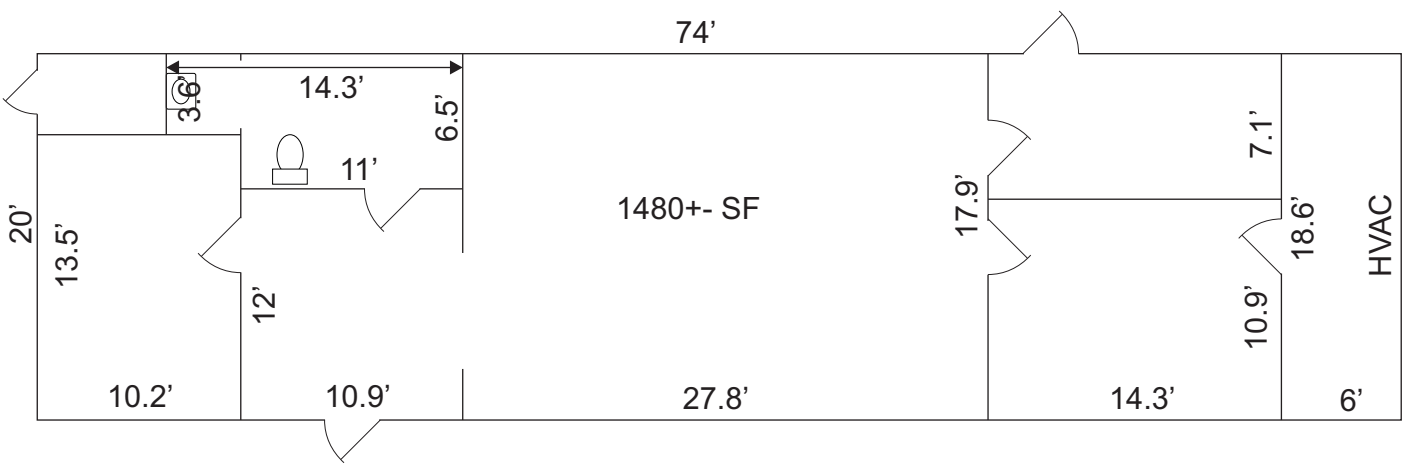

2 CARPORT BEHIND BUILDING:
18' x 21' & 16' x 22'

