

LANGSTON BLACK

REAL ESTATE, INC.

SPACE AVAILABLE FOR LEASE

12992 EAST WADE HAMPTON BLVD., DUNCAN



SUITE B
1,560+- SF
OFFICE
AREA

CORNER OF
GAP CREEK
ROAD AND
WADE
HAMPTON
BLVD.
(HWY 29)



LEASE RATE: SUITE B: \$800/MONTH

FOR MORE INFORMATION CONTACT
BRAD TOY AT 640-7429
btoy@langston-black.com

LANGSTON BLACK
REAL ESTATE, INC.

P.O. BOX 2167
GREER, S.C. 29652
BUS: 864-848-9070

443

www.langston-black.com

Every effort has been made to ensure the accuracy of the enclosed data, but we assume no responsibility for errors. All conditions and pricing subject to change without notice.
(LANGSTON-BLACK SITE #443)

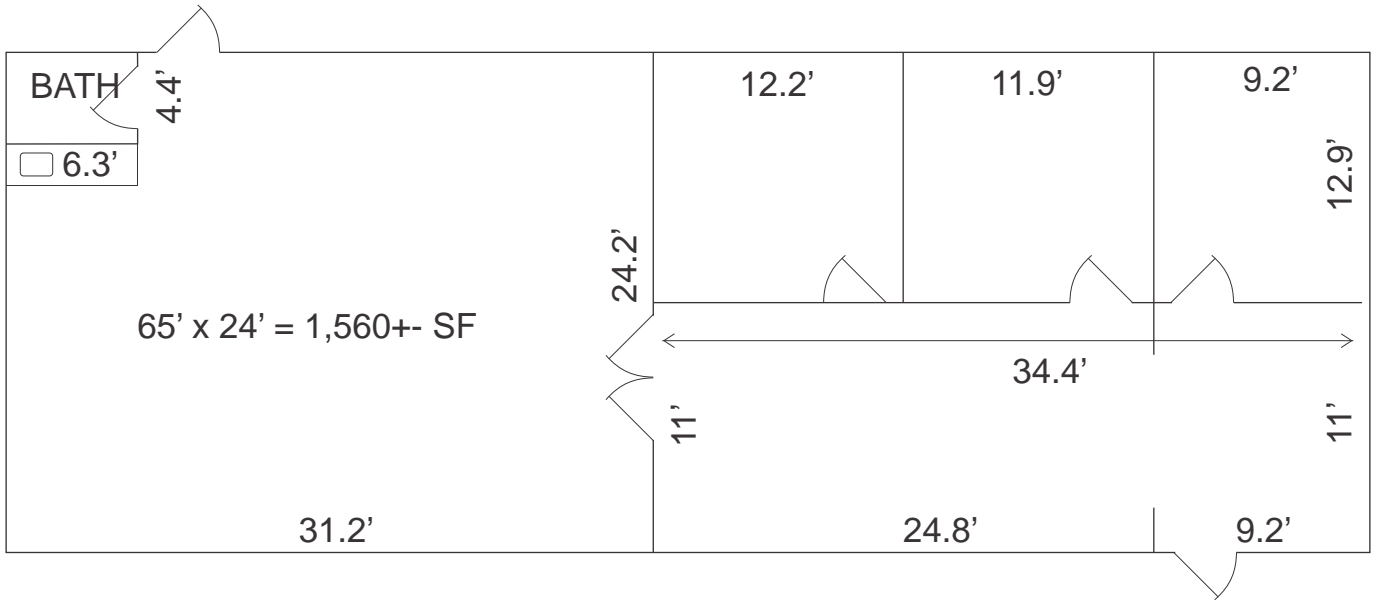

BUILDING HAS 5 UNITS
 UNIT ADDRESS NUMBERS:
 12990
 12992
 12994
 12996
 12998

12998 IS LEFT MOST UNIT AND
 12990 IS TUCK & HOWELL (RIGHT MOST UNIT)